

## SIEMENS-FLENDER MACHINES **B.K. FOR SIEMENS**

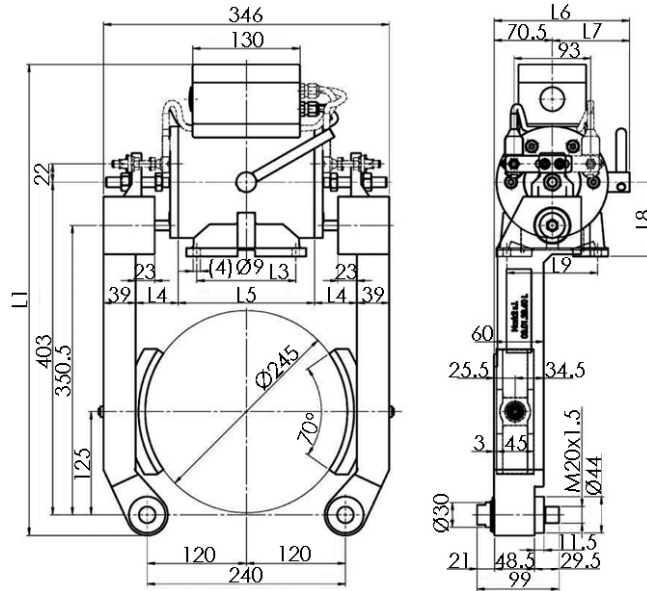

**Brake kits for Siemens-Flender machines.G26-10-11-13**

REFERENCE	DUTY CYCLE	BRAKE TORQUE [Nm]
Siemens G26-10-11-13 machine kit	100% ED	2x 20 ... 2x 250

Power supply: 230VAC with additional overexcitation box  
2/4 microswitches

**Brake kits for Siemens-Flender machines.G26-10-11-13**

REFERENCE	L1	L3	L4	L5	L6	L7	L8	L9
Siemens G26-10 machine kit	552,5	80	66	136	141,5	71	60	100
Siemens G26-11 machine kit	561	90	64	140	153,5	83	75	100
Siemens G26-13 machine kit	571	120	51,5	165	164	93,5	90	110



## SIEMENS-FLENDER MACHINES **B.K. FOR SIEMENS**

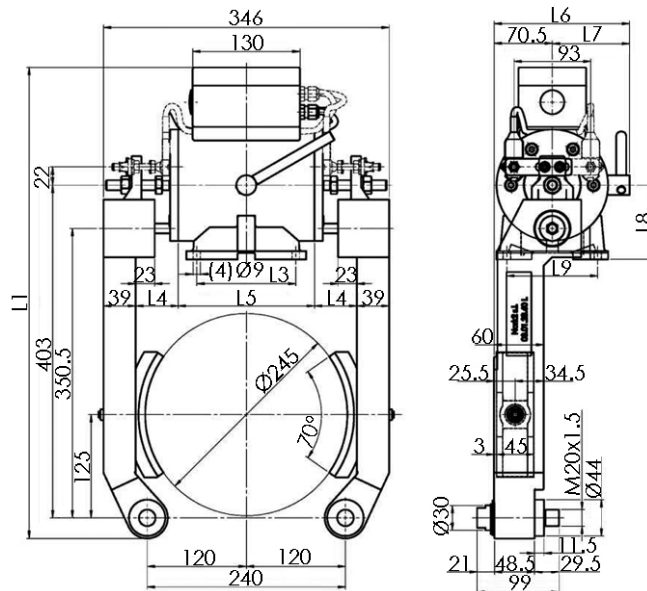

Brake kits for Siemens-Flender machines.G26-16

REFERENCE	DUTY CYCLE	BRAKE TORQUE [Nm]
Siemens G26-16 machine kit	100% ED	2x 20 ... 2x 250

Power supply: 230VAC with additional overexcitation box

